

Engineering Specification

Job Name _____
 Job Location _____
 Engineer _____
 Approval _____
 Tag _____

Contractor _____
 Approval _____
 Contractor's P.O. No. _____
 Representative _____

FD-190-PR-60 PVC Adjustable Floor Drain with Integrated Level



Specification

Watts Pronto!® FD-190-PR-60 PVC floor drain with anchor flange, reversible clamping collar with primary and secondary weepholes, post-pour adjustable round heel proof nickel bronze strainer with integrated bubble level, leveling shims, and PVC socket outlet.

Pipe Size		
Suffix	Description	
2	2"(51) Pipe Size	<input type="checkbox"/>
3	3"(76) Pipe Size	<input type="checkbox"/>
4	4"(102) Pipe Size	<input type="checkbox"/>

Strainer		
Suffix	Description	
PR5	5"(127) Dia., Nickel Bronze	<input type="checkbox"/>
PR6	6"(152) Dia., Nickel Bronze	<input type="checkbox"/>
PR7	7"(178) Dia., Nickel Bronze	<input type="checkbox"/>
PR8	8"(203) Dia., Nickel Bronze	<input type="checkbox"/>

Options		
Suffix	Description	
-6	Vandal Proof	<input type="checkbox"/>
-7	Trap Primer Tapping	<input type="checkbox"/>
-8	Backwater Valve (2, 3, 4" Only)	<input type="checkbox"/>
-F4-50	4" Round Cast Iron Funnel	<input type="checkbox"/>
-F4-1	4" Round Nickel Bronze Funnel	<input type="checkbox"/>
-F6-1	6" Round Nickel Bronze Funnel	<input type="checkbox"/>
-G-50	4x9" Oval Cast Iron Funnel	<input type="checkbox"/>
-G-1	4x9" Oval Nickel Bronze Funnel	<input type="checkbox"/>

Strainer Dia.	Min.	Max.	Load Rating	Free Area Sq. In.
5"(127)	2 1/2"(64)	4 1/4"(108)	MD	6
6"(152)	2 1/2"(64)	4 1/4"(108)	LD	11
7"(178)	2 5/8"(67)	4 3/8"(111)	LD	13
8"(203)	2 3/4"(70)	4 1/2"(114)	MD	19

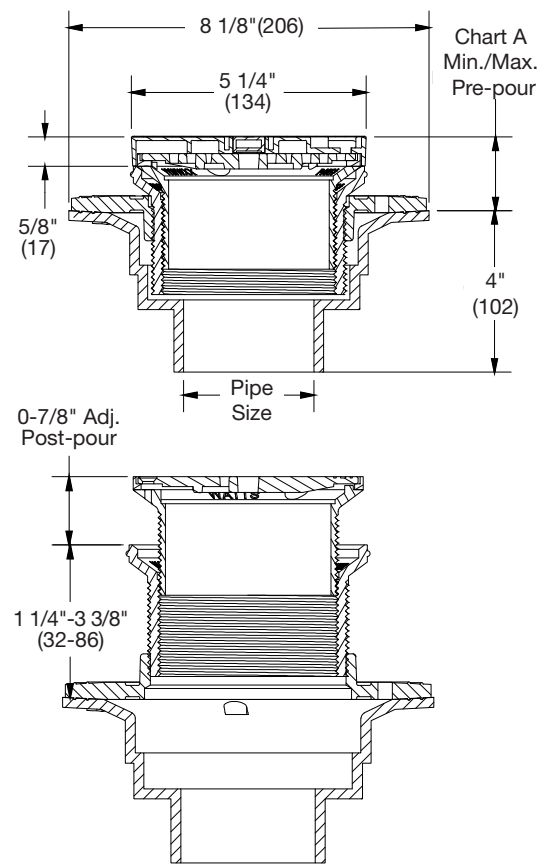

NOTICE

The information contained herein is not intended to replace the full product installation and safety information available or the experience of a trained product installer. You are required to thoroughly read all installation instructions and product safety information before beginning the installation of this product.

Watts product specifications in U.S. customary units and metric are approximate and are provided for reference only. For precise measurements, please contact Watts Technical Service. Watts reserves the right to change or modify product design, construction, specifications, or materials without prior notice and without incurring any obligation to make such changes and modifications on Watts products previously or subsequently sold.



USA: T: (800) 338-2581 • F: (828) 248-3929 • Watts.com
Canada: T: (888) 208-8927 • F: (905) 479-2316 • Watts.ca
Latin America: T: (52) 55-4122-0138 • Watts.com